



Asia Trafo Co., Ltd

SPECIFICATION OF OIL IMMERSED CURRENT TRANSFORMER

CURRENT TRANSFORMER SPECIFICATION

22 kV 400/5/5 A. 50 Hz.

30VA. Class 0.5 (5P20)

88/99 หมู่ 12 ซ.สุนทรวิภาต อ.บางพลี - ตำบล ต.บางปลา อ.บางพลี จ.สมุทรปราการ 10540 Tel. (02) 346-0980-7 Fax. (02) 346-0978-9

88/99 Moo.12 Soi sunthonwipark Bangplee -tumroo Road Bangpra Bangplee samuthprakarn 10540 Tel. (02) 346-0980-7 Fax. (02) 346-0978-9

SPEC NO.

S-CT22000-400/5/5 A

Page 1/3



Asia Trafo Co., Ltd

SPECIFICATION OF OIL IMMERSED CURRENT TRANSFORMER

TECHNICAL DATA FOR 22 kV 400/5/5 A. 50 Hz. 30VA. Class 0.5 (5P20) FS < 5

No.	Description	Unit	Guaranteed Value		
	22 kV 400/5/5 A current transformers				
1	Manufacture's name	-	ASIA TRAF0 CO.,LTD.		
2	Country of origin	-	Thailand		
3	Type of transformer	-	Outdoor Installation		
4	Applied standard	-	IEC 61869-1, IEC 61869-2		
5	Type of outer insulation	-	Oil Immersed		
	Rating				
7	Nominal voltage	kV	22		
8	Highest voltage for equipment Um	kV	24		
9	Rated primary current	A	400		
10	Rated secondary current	A	5/5		
11	Rated frequency	Hz	50		
12	Rated Burden				
	- Core 1	VA	30		
	- Core 2	VA	30		
13	Accuracy class				
	- Core 1	-	0.5		
	- Core 2	-	5P20		
14	Minimum nominal specific creepage distance	mm/kV	≥ 25		
15	Rated power frequency withstand voltage on primary and secondary winding	kV,r.m.s	50/3		
16	Rated lightning impulse withstand voltage	kV,peak	125		
17	Class of insulation	-	A (105 °C)		
18	Rated short-time thermal current (Ith), 1s	kA	0.1 x In		
19	Rated dynamic current (Idyn)	kA	2.5 x Ith		
	Weight / dimensions and installation				
20	Primary terminals / Primary connector	-	NEMA Pad/ 4 holes		
21	Secondary terminals	-	Brass threaded stud type / M6		
22	Earth terminal	-	for 35-50 mm ²		
23	Altitude	-	Up to 1,000 m above sea level		
24	Maximum temperature-rise test of winding	k	60		
25	Maximum ambient temperature	°C	40		
26	Dimension (WxLxH)	mm	298 x 500 x 720		
27	Total weight (approx.)	kg	50		
	Other				
28	Accessories as per the specification	-	Yes		
	Test requirements				
29	Type test reports	-	Yes		
30	Routine test reports	-	Yes		
Rev	Date	Prepared by	Checked by	Approved by	Signature
00	12/6/2566	รัฐมนตรา	กิตติ	กิตติ	
SPEC NO.	S-CT22000-400/5/5 A			Page 2/3	



Asia Trafo Co., Ltd

SPECIFICATION OF OIL IMMERSED CURRENT TRANSFORMER

Accessories

- HV & LV Bushing with terminal connectors
- Bird guard cap
- Earthing terminal
- Other ... Factory standard

Routine test

- Verification marking
- Insulation resistance
- Power frequency voltage withstand tests on primary terminals
- Power frequency voltage withstand test on secondary terminals
- Partial discharge measurement
- Inter-turn overvoltage test
- Test for accuracy

■ with

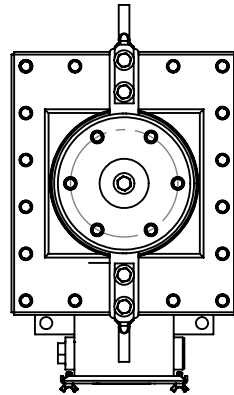
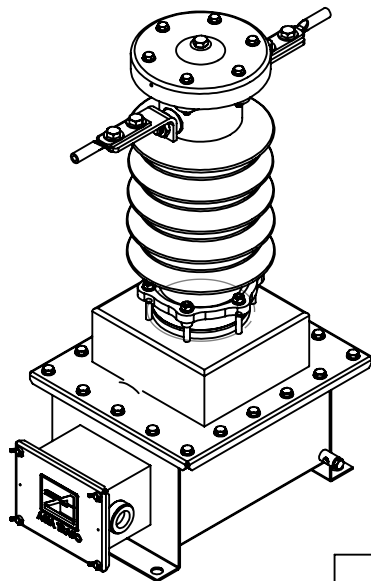
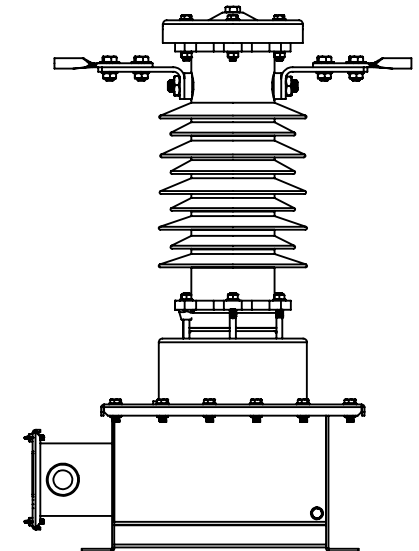
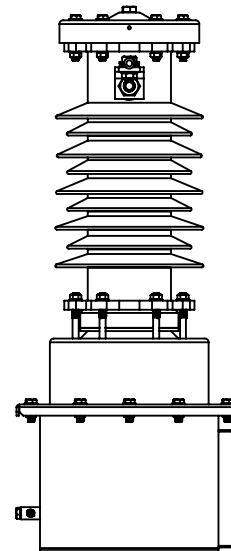
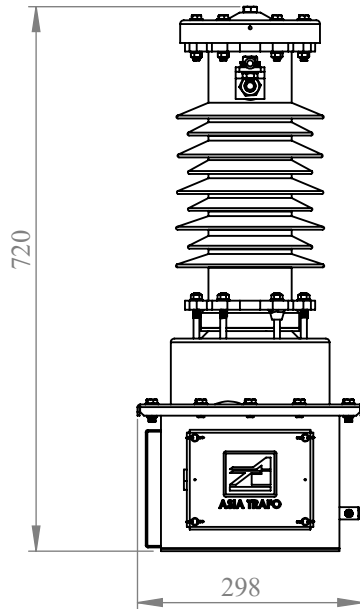
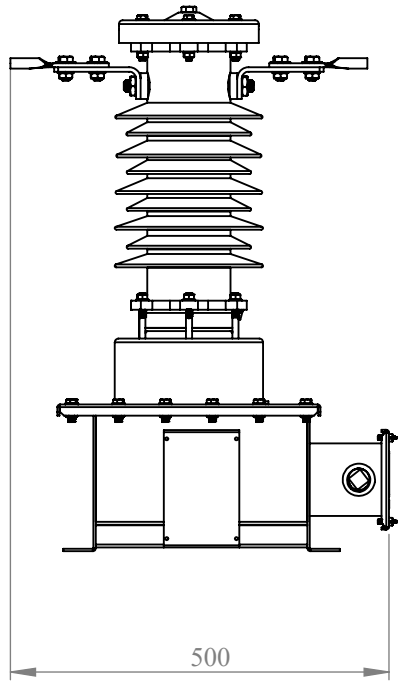

□ without

Rev	Date	Prepared by	Checked by	Approved by	Signature
00	12/6/2566	รัฐมนตรา	กิตติ	กิตติ	
SPEC NO.	S-CT22000-400/5/5 A				Page 3/3



Dimension in millimeter				
H	L	W	Weight	Oil
720	481	298	50	9

Rev.No.	Revision Note
△	
△	

 บริษัท เอเชีย ทราฟิโ จำกัด ASIA TRAFICO CO.,LTD	MODEL/DESCRIPTION: CT 400/5-5 A	
	DWG: 400/5-22-02	
 DIMENSION IN MILLIMETER		
DESIGNED	NAME รัฐมนตรา	DATE 12/6/2566
CHECKED	กิตติ	12/6/2566
APPROVED	กิตติ	12/6/2566
WORK NO :		QTY.....EA
SCALE:		REV:0
		SHEET 1 OF 1

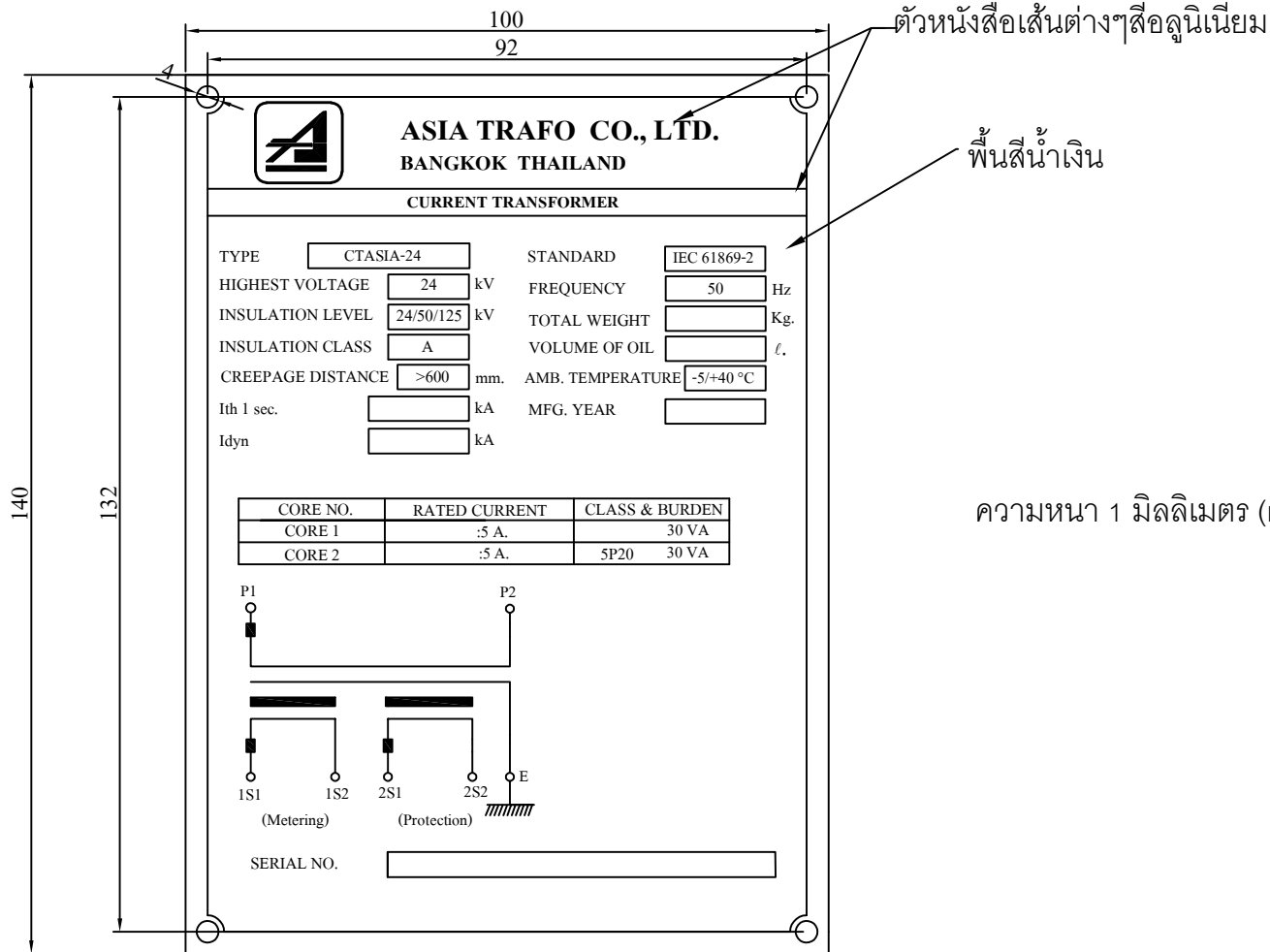

หน่วย : มิลลิเมตร (mm)



บริษัท เอเชีย ทราฟิ จำกัด
ASIA TRAF0 CO.,LTD



DIMENSION IN MILLIMETER

△	
△	
Rev No.	Revision Note.

	NAME	DATE
DESIGNED	รัฐมนตรา	12/6/2566
CHECK	กิตติ	12/6/2566
APPROVED	กิตติ	12/6/2566

MODEL/DESCRIPTION : Name Plate CT 22 kV 5P20	
DWG.No : 400/5-22-02	
WORK NO : QTY..... EA	
SCALE :	
REV : 00	SHEET 1 OF 1