



Asia Trafo Co., Ltd

SPECIFICATION OF OIL IMMERSED VOLTAGE TRANSFORMER

VOLTAGE TRANSFORMER SPECIFICATION

22000/ $\sqrt{3}$ -110/ $\sqrt{3}$ V ; 40 VA Class1

22000/ $\sqrt{3}$ -220 V ; 500 VA 10% Voltage Regulation

88/99 หมู่ 12 ซ. สุนทรวิภาค อ.บางพลี - ตำหารุ ต.บางปลา อ.บางพลี จ.สมุทรปราการ 10540 Tel. (02) 346-0980-7 Fax. (02) 346-0978-9

88/99 Moo.12 Soi sunthonwipark Bangplee -tumroo Road Bangpra Bangplee samuthprakarn 10540 Tel. (02) 346-0980-7 Fax. (02) 346-0978-9

SPEC NO.

S-VT22000/ $\sqrt{3}$ -110/ $\sqrt{3}$ -220 V

Page 1/3



Asia Trafo Co., Ltd

SPECIFICATION OF OIL IMMERSED VOLTAGE TRANSFORMER

TECHNICAL DATA FOR 22000/ $\sqrt{3}$ -110/ $\sqrt{3}$ V ; 40 VA Class1, 22000/ $\sqrt{3}$ -220 V ; 500 VA 10%

No.	Description	Unit	Guaranteed Value		
	22000/$\sqrt{3}$-110/$\sqrt{3}$-220 V voltage transformers				
1	Manufacture's name	-	ASIA TRAF0 CO.,LTD.		
2	Country of origin	-	Thailand		
3	Type of transformer	-	Outdoor Installation, 3 Phase		
4	Applied standard	-	IEC 61869-1, IEC 61869-3		
5	Type of outer insulation	-	Oil Immersed		
	Rating				
7	Norminal voltage	kV	22		
8	Highest voltage for equipment Um	kV	24		
9	Connection Winding	-	YNyn0		
10	Rated primary voltage	V	22000/ $\sqrt{3}$		
11	Rated secondary voltage				
	- Voltage signal for FRTU	V	110/ $\sqrt{3}$		
	- Power supply for the control unit	V	220		
12	Rated frequency	Hz	50		
13	Rated Burden & Accuracy class				
	- Voltage signal for FRTU	-	not less than 40 VA, Class 1		
	- Power supply for the control unit	-	not less than 500 VA, 10% voltage regulation at P.F. = 1		
14	Rated voltage factor	-	1.2 Continuous and 1.5 at 30 sec		
15	Minimum nominal specific creepage distance	mm/kV	≥ 25		
16	Rated power frequency withstand voltage on primary and secondary winding	kVrms	50/3		
17	Rated lightning impulse withstand voltage	kVpeak	125		
18	Class of insulation	-	A (105 °C)		
	Weight / dimensions and installation				
19	Primary terminals / Primary connector	-	Solderless clamp type terminal connector		
20	Secondary terminals	-	Brass stud type / M6		
21	Earth terminal	-	for 50-95 mm ² ACSR conductor		
22	Altitude	-	Up to 1,000 m above sea level		
23	Maximum temperature-rise test of winding	k	60		
24	Maximum ambient temperature	°C	40		
25	Dimension (WxLxH)	mm	657 x 886 x 777		
26	Total weight (approx.)	kg	≤ 200		
	Other				
27	Accessories as per the specification	-	Yes		
	Test requirements				
28	Type test reports	-	Yes		
29	Routine test reports	-	Yes		
Rev	Date	Prepared by	Checked by	Approved by	Signature
00	12/6/2566	รัฐมนตรา	กิตติ	กิตติ	
SPEC NO.	S-VT22000/ $\sqrt{3}$ -110/ $\sqrt{3}$ -220 V				Page 2/3



Asia Trafo Co., Ltd

SPECIFICATION OF OIL IMMERSED VOLTAGE TRANSFORMER

Accessories

- HV & LV Bushing with terminal connectors
- Name plate
- Bird guard cap
- Earthing terminal
- Other ... Factory standard

Type test

- Temperature-rise test
- Short-circuit withstand capability test
- Impulse voltage withstand test on primary terminals
- Wet test for outdoor type transformer
- Test for accuracy
- Partial discharge measurement
- Voltage transformer's tank pressure test
- Voltage Regulation Test

Routine test

- Verification marking
- Insulation resistance
- Power frequency voltage withstand tests on primary terminals
- Power frequency voltage withstand test on secondary terminals
- Partial discharge measurement
- Induce overvoltage withstand test
- Test for accuracy
- Voltage Regulation Test

■ with

□ without

Rev	Date	Prepared by	Checked by	Approved by	Signature
00	12/6/2566	รัฐมนตรา	กิตติ	กิตติ	
SPEC NO.	S-VT22000/√3-110/√3-220 V				Page 3/3

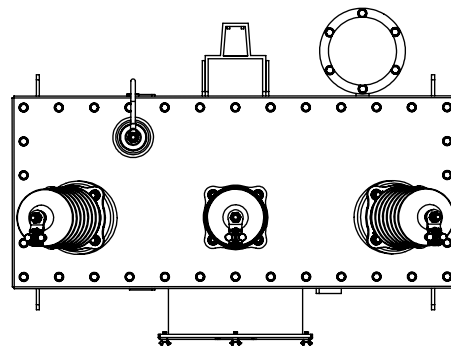
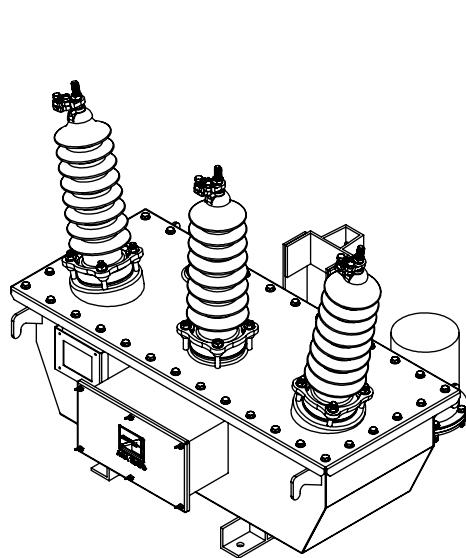
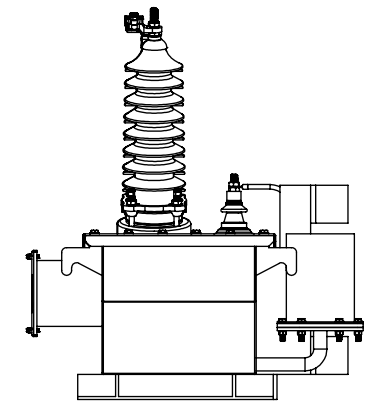
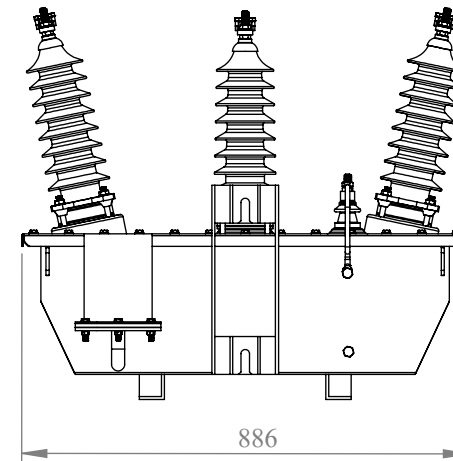
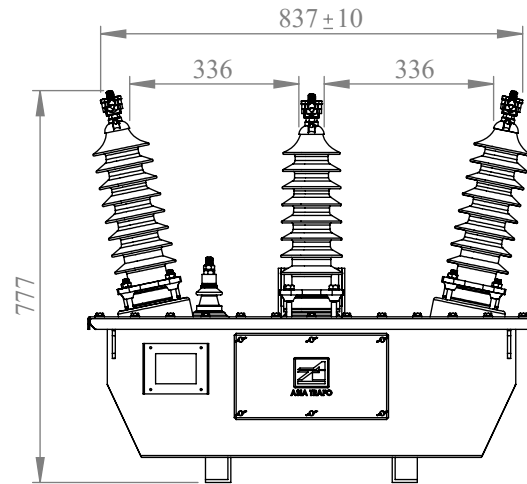
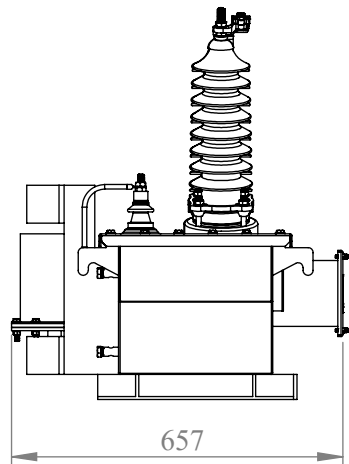

Dimension in millimeter				
H	L	w	Weight	Oil
777	886	657	185	40



บริษัท เอเชีย ทราฟโ จำกัด
ASIA TRAFKO CO., LTD

MODEL/DESCRIPTION:
VT 3P 22000/sqr3-110/sqr3-220 V

DWG: 3P-22-04

⌀ DIMENSION IN MILLIMETER

Rev.No.	Revision Note

	NAME	DATE
DESIGNED	รัฐมนตรา	12/6/2566
CHECKED	กิตติ	12/6/2566
APPROVED	กิตติ	12/6/2566

WORK NO : QTY.....EA

SCALE:

REV:02 SHEET 1 OF 1

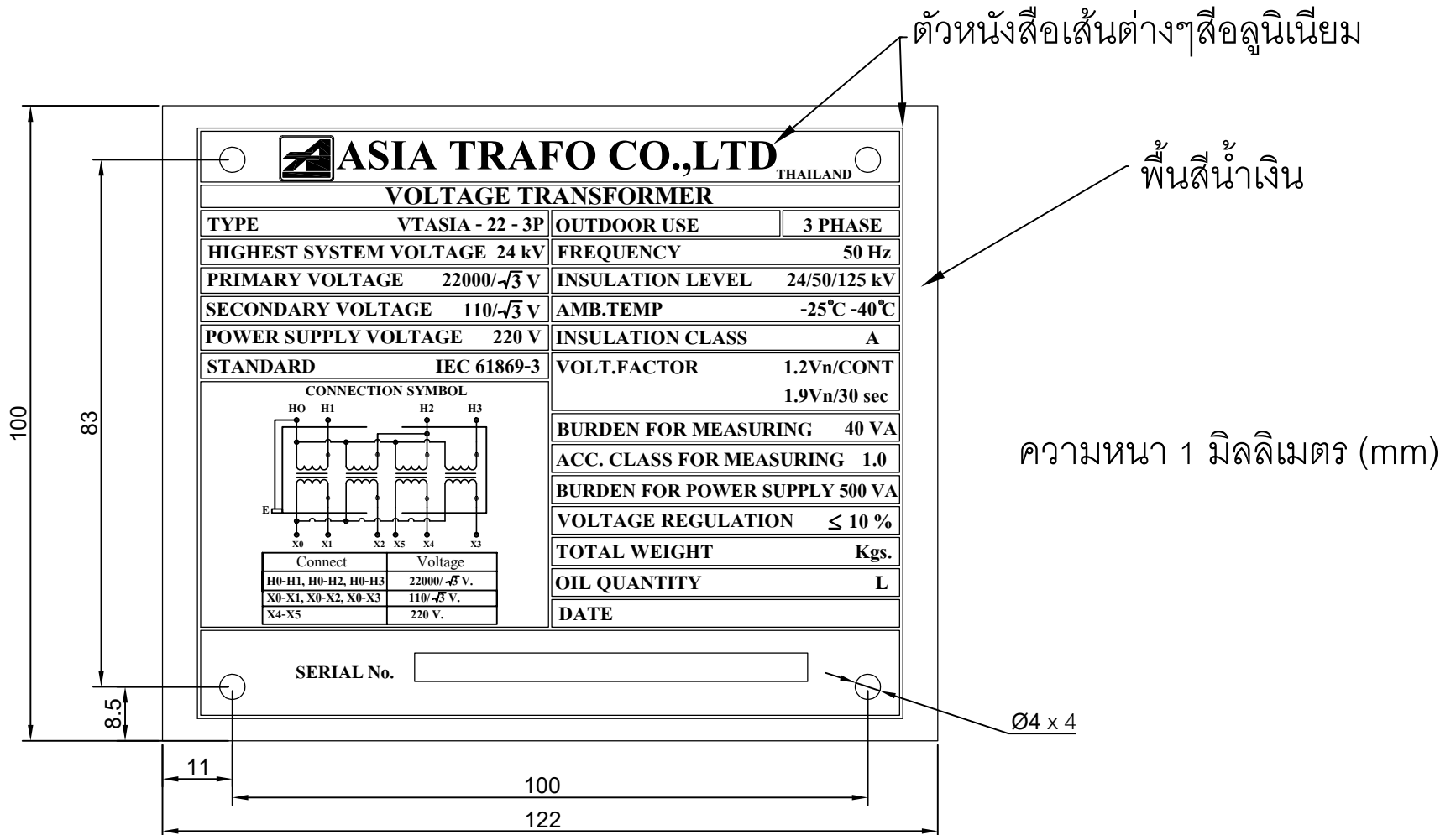

หน่วย : มิลลิเมตร (mm)

	บริษัท เอเชีย ทราฟิ จำกัด ASIA TRAF0 CO.,LTD		MODEL/DESCRIPTION :	Nameplate VT 22000sqr3-110sqr3-220 V	
	DIMENSION IN MILLIMETER		DWG.No :	3P-22-04	
	NAME	DATE	WORK NO :	QTY..... EA	
	DESIGNED	รัฐมนตรา	12/6/2566		
	CHECK	กิตติ	12/6/2566	SCALE :	
Rev No.	Revision Note.	APPROVED	กิตติ	12/6/2566	REV : 00
					SHEET 1 OF 1