



Asia Trafo Co., Ltd
SPECIFICATION OF OIL IMMERSED VOLTAGE TRANSFORMER

VOLTAGE TRANSFORMER SPECIFICATION

33000/110 V 1Ph. 50 Hz.

50VA. Class 0.5

88/99 หมู่ 12 ซ. สุนทรวิภาค ถ.บางพลี - ตำหนุ ต.บางปลา อ.บางพลี จ.สมุทรปราการ 10540 Tel. (02) 346-0980-7 Fax. (02) 346-0978-9

88/99 Moo.12 Soi sunthonwipark Bangplee -tumroo Road Bangpra Bangplee samuthprakarn 10540 Tel. (02) 346-0980-7 Fax. (02) 346-0978-9

SPEC NO.

S-VT33000-110V

Page 1/3



Asia Trafo Co., Ltd

SPECIFICATION OF OIL IMMERSED VOLTAGE TRANSFORMER

TECHNICAL DATA FOR 33000/110 V 1Ph. 50 Hz. 50VA. Class 0.5

No.	Description	Unit	Guaranteed Value		
33/0.11 kV voltage transformers					
1	Manufacture's name	-	ASIA TRAF0 CO.,LTD.		
2	Country of origin	-	Thailand		
3	Type of transformer	-	Outdoor Installation, 1 Phase		
4	Applied standard	-	IEC 61869-1, IEC 61869-3		
5	Type of outer insulation	-	Oil Immersed		
Rating					
7	Norminal voltage	kV	33		
8	Highest voltage for equipment Um	kV	36		
9	Rated primary voltage	kV	33		
10	Rated secondary voltage	V	110		
11	Rated frequency	Hz	50		
12	Rated Burden	VA	50		
13	Accuracy class	-	0.5		
14	Rated voltage factor	-	1.2 Continuous and 1.5 at 30 sec		
15	Minimum nominal specific creepage distance	mm/kV	≥ 25		
16	Rated power frequency withstand voltage on primary and secondary winding	kVrms	70/3		
17	Rated lightning impulse withstand voltage	kVpeak	170		
18	Class of insulation	-	A (105 °C)		
Weight / dimensions and installation					
19	Primary terminals / Primary connector	-	Solderless clamp type terminal connector		
20	Secondary terminals	-	Brass stud type / M6		
21	Earth terminal	-	for 35-50 mm ² ACSR conductor		
22	Altitude	-	Up to 1,000 m above sea level		
23	Maximum temperature-rise test of winding	k	60		
24	Maximum ambient temperature	°C	40		
25	Dimension (WxLxH)	mm	441 x 762 x 815		
26	Total weight (approx.)	kg	≤70		
Other					
27	Accessories as per the specification	-	Yes		
Test requirements					
28	Type test reports	-	Yes		
29	Routine test reports	-	Yes		
Rev	Date	Prepared by	Checked by	Approved by	Signature
00	12/6/2566	รัฐมนตรี	กิตติ	กิตติ	
SPEC NO.	S-VT33000-110V				Page 2/3



Asia Trafo Co., Ltd

SPECIFICATION OF OIL IMMERSED VOLTAGE TRANSFORMER

Accessories

- HV & LV Bushing with terminal connectors
- Name plate
- Bird guard cap
- Earthing terminal
- Other ... Factory standard

Type test

- Temperature-rise test
- Short-circuit withstand capability test
- Lightning impulse test
- Wet test for outdoor type transformer
- Test for accuracy

Routine test

- Verification marking
- Insulation resistance
- Power frequency voltage withstand tests on primary terminals
- Power frequency voltage withstand test on secondary terminals
- Partial discharge measurement
- Induce overvoltage withstand test
- Test for accuracy

with

without

Rev	Date	Prepared by	Checked by	Approved by	Signature
00	12/6/2566	รัฐมนตรา	กิตติ	กิตติ	
SPEC NO.	S-VT33000-110V				Page 3/3

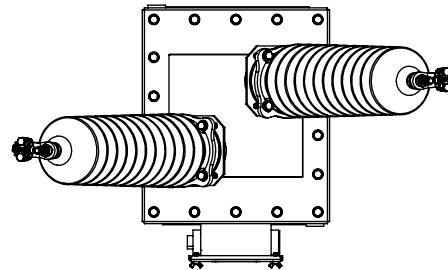
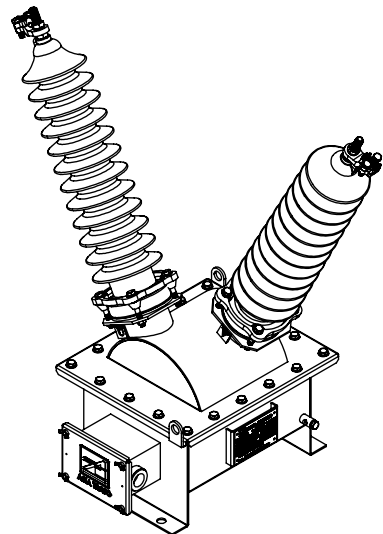
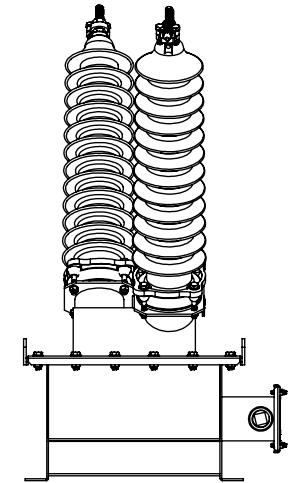
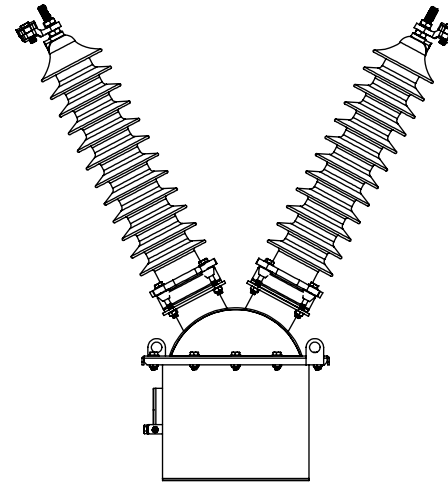
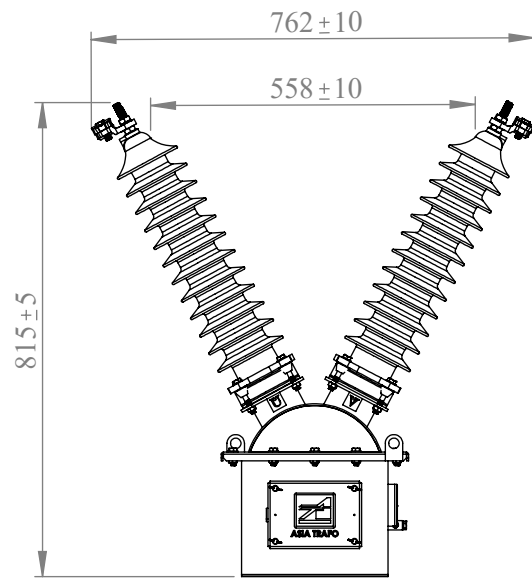
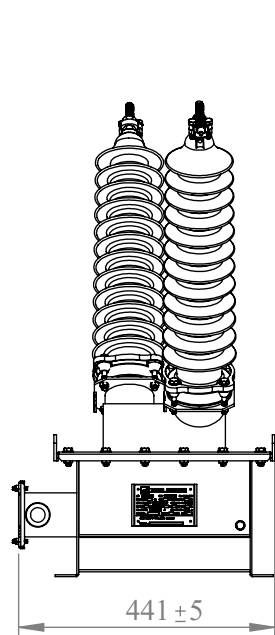

Dimension in millimeter				
H	L	W	Weight	Oil
815	762	441		



บริษัท เอเชีย ทราฟ จำกัด
ASIA TRAFKO CO.,LTD



DIMENSION IN MILLIMETER

MODEL/DESCRIPTION:
VT 33000-110 V

DWG:
1P-33-01

WORK NO :
QTY.....EA

△		DESIGNED	รัฐมนตรา	12/6/2566
△		CHECKED	กิตติ	12/6/2566
Rev.No.	Revision Note	APPROVED	กิตติ	12/6/2566

SCALE:
REV:0 SHEET 1 OF 1

ขอบนอกช่องตัวหนังสือและเส้น (สื่อลูมิเนียม)

พื้น+ตัวหนังสือในช่อง(สีน้ำเงิน)

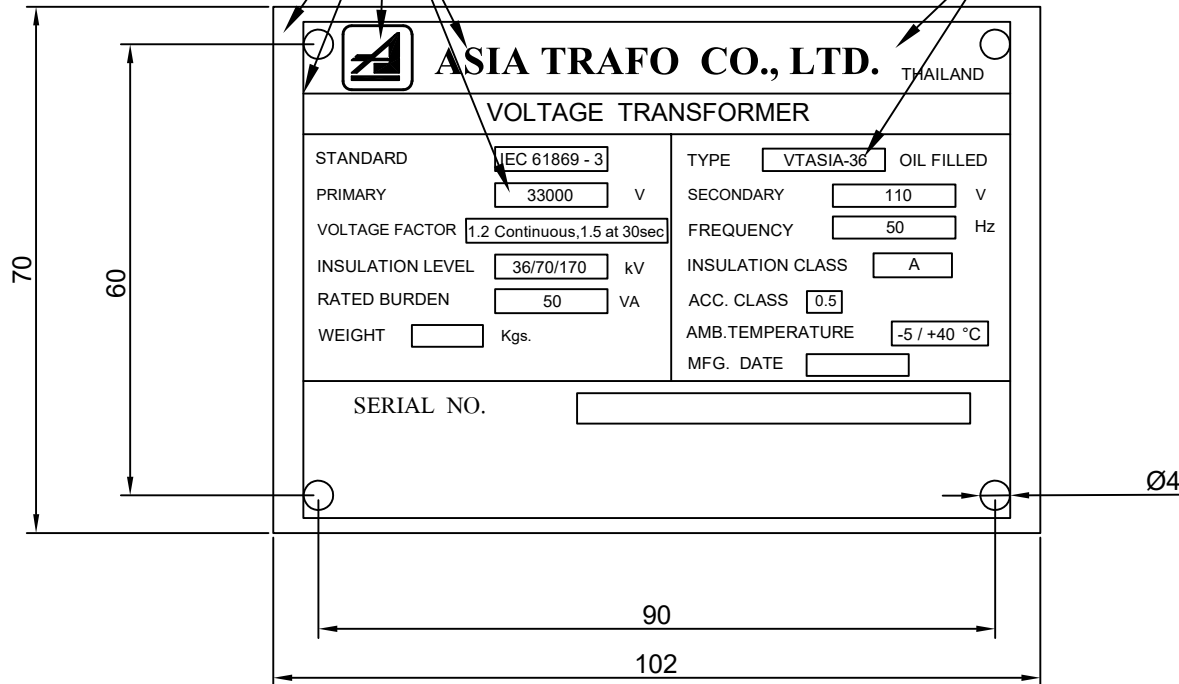

หน่วย : มิลลิเมตร (mm)

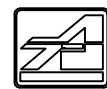

บริษัท เอเชีย ทราฟิ จำกัด
ASIA TRAF0 CO.,LTD

MODEL/DESCRIPTION :

VT 33000-110 V

DWG.No :

1P-33-01

⊕ DIMENSION IN MILLIMETER

WORK NO :

QTY..... EA



Rev No.

Revision Note.

DESIGNED

NAME

DATE

รัฐมนตรา

12/6/2566

CHECK

กิตติ

12/6/2566

APPROVED

กิตติ

12/6/2566

SCALE :

REV : 00

SHEET 1 OF 1