



Asia Trafo Co., Ltd

SPECIFICATION OF OIL IMMERSED VOLTAGE TRANSFORMER

VOLTAGE TRANSFORMER SPECIFICATION

33000/ $\sqrt{3}$ - 110/ $\sqrt{3}$ - 110/ $\sqrt{3}$ V 3Ph. 50 Hz.

50VA. Class 0.5

88/99 หมู่ 12 ซ.สุนทรวิภาต ถ.บางพลี - ตำหนุ ด.บางปลา อ.บางพลี จ.สมุทรปราการ 10540 Tel. (02) 346-0980-7 Fax. (02) 346-0978-9

88/99 Moo.12 Soi sunthonwipark Bangplee -tumroo Road Bangpra Bangplee samuthprakarn 10540 Tel. (02) 346-0980-7 Fax. (02) 346-0978-9

SPEC NO.

S-VT33000/ $\sqrt{3}$ - 110/ $\sqrt{3}$ - 110/ $\sqrt{3}$ V

Page 1/3



Asia Trafo Co., Ltd

SPECIFICATION OF OIL IMMERSED VOLTAGE TRANSFORMER

TECHNICAL DATA FOR 33000/ $\sqrt{3}$ - 110/ $\sqrt{3}$ - 110/ $\sqrt{3}$ V 3Ph. 50 Hz. 50VA. Class 0.5

No.	Description	Unit	Guaranteed Value		
	33000/$\sqrt{3}$ - 110/$\sqrt{3}$ - 110/$\sqrt{3}$ V voltage transformers				
1	Manufacture's name	-	ASIA TRAF0 CO.,LTD.		
2	Country of origin	-	Thailand		
3	Type of transformer	-	Outdoor Installation, 3 Phase		
4	Applied standard	-	IEC 61869-1, IEC 61869-3		
5	Type of outer insulation	-	Oil Immersed		
	Rating				
7	Norminal voltage	kV	33		
8	Highest voltage for equipment Um	kV	36		
9	Connection Winding	-	YNyn0		
10	Rated primary voltage	V	33000/ $\sqrt{3}$		
11	Rated secondary voltage				
	- Voltage Measuring (YNyn0)	V	110/ $\sqrt{3}$		
	- Voltage Protection (YNyn0)	V	110/ $\sqrt{3}$		
12	Rated frequency	Hz	50		
13	Rated Burden	VA	50		
14	Accuracy class (Measuring/Protection)	-	0.5/3P		
15	Rated voltage factor	-	1.2 Continuous and 1.5 at 30 sec		
16	Minimum nominal specific creepage distance	mm/kV	≥ 25		
17	Rated power frequency withstand voltage on primary and secondary winding	kVrms	70/3		
18	Rated lightning impulse withstand voltage	kVpeak	170		
19	Class of insulation	-	A (105 °C)		
	Weight / dimensions and installation				
20	Primary terminals / Primary connector	-	Solderless clamp type terminal connector		
21	Secondary terminals	-	Brass stud type / M6		
22	Earth terminal	-	for 50-95 mm ² ACSR conductor		
23	Altitude	-	Up to 1,000 m above sea level		
24	Maximum temperature-rise test of winding	k	60		
25	Maximum ambient temperature	°C	40		
26	Dimension (WxLxH)	mm	680 x 865 x 908		
27	Total weight (approx.)	kg	≤ 165		
	Other				
28	Accessories as per the specification	-	Yes		
	Test requirements				
29	Type test reports	-	Yes		
30	Routine test reports	-	Yes		
Rev	Date	Prepared by	Checked by	Approved by	Signature
00	12/6/2566	รัฐมนตรา	กิตติ	กิตติ	
SPEC NO.	S-VT33000/ $\sqrt{3}$ - 110/ $\sqrt{3}$ - 110/ $\sqrt{3}$ V				Page 2/3



Asia Trafo Co., Ltd

SPECIFICATION OF OIL IMMERSED VOLTAGE TRANSFORMER

Accessories

- HV & LV Bushing with terminal connectors
- Name plate
- Bird guard cap
- Earthing terminal
- Other ... Factory standard

Routine test

- Verification marking
- Insulation resistance
- Power frequency voltage withstand tests on primary terminals
- Power frequency voltage withstand test on secondary terminals
- Partial discharge measurement
- Induce overvoltage withstand test
- Test for accuracy

■ with

□ without

Rev	Date	Prepared by	Checked by	Approved by	Signature
00	12/6/2566	รัฐมนตรา	กิตติ	กิตติ	
SPEC NO.	S-VT33000/ $\sqrt{3}$ - 110/ $\sqrt{3}$ - 110/ $\sqrt{3}$ V				Page 3/3

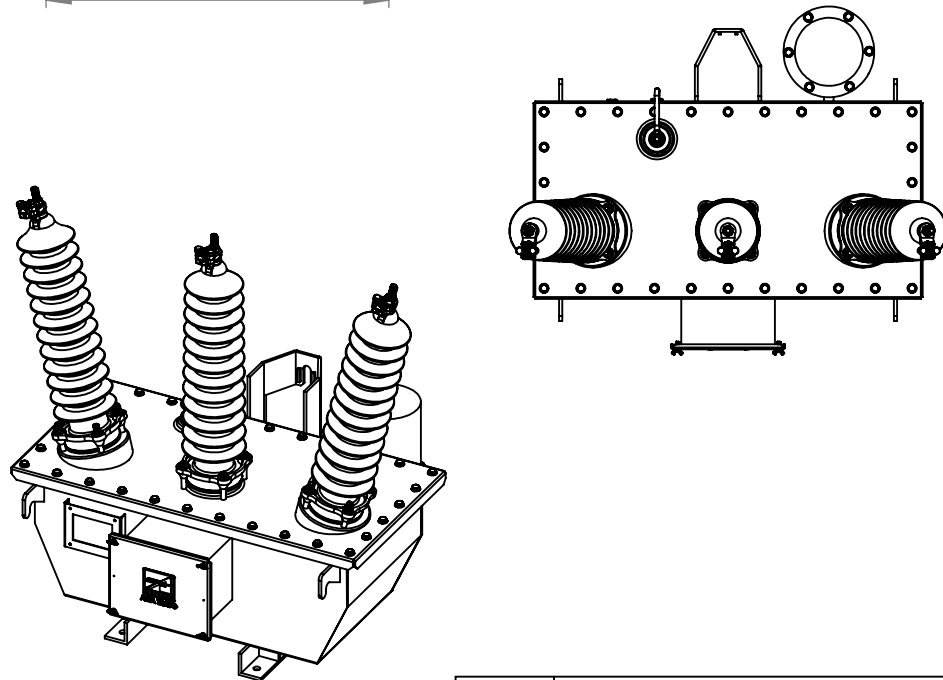
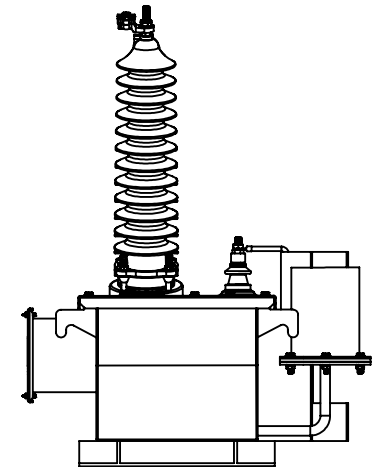
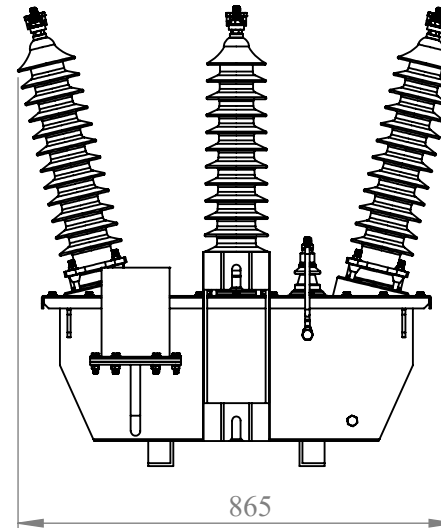
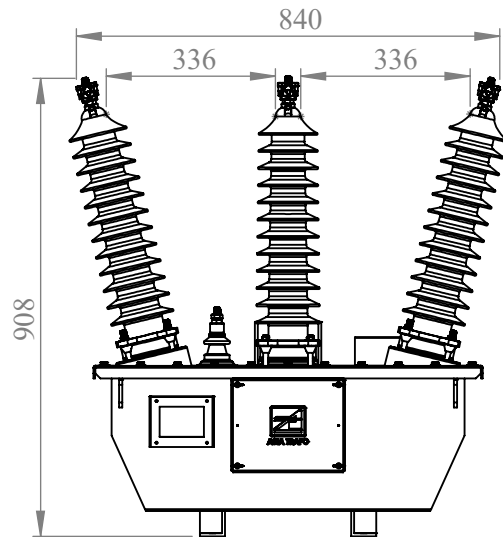
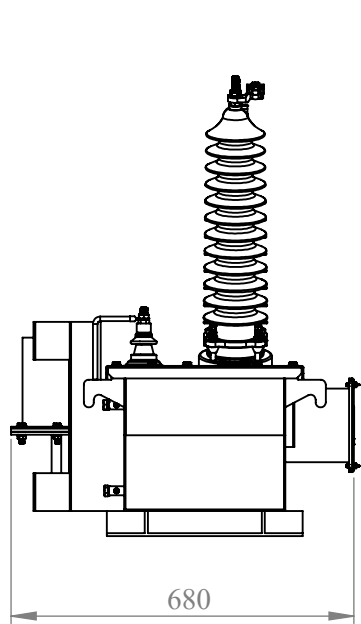

Dimension in millimeter				
H	L	W	Weight	Oil
908	865	680		

 บริษัท เอเชีย ทราโฟ จำกัด ASIA TRAFKO CO.,LTD	MODEL/DESCRIPTION: VT 3P 33000/sqr3 -110/sqr3-110sqr3 V		
	DWG: 3P-33-02		
⌀ DIMENSION IN MILLIMETER		WORK NO :	
△ DESIGNED	รัชมนตรา	12/6/2566	QTY.....EA
△ CHECKED	กิตติ	12/6/2566	SCALE:
Rev.No.	Revision Note	APPROVED	กิตติ
		12/6/2566	REV:0
			SHEET 1 OF 10

ตัวหนังสือเส้นต่างๆ ล้อลูนิเนียม

พื้นสีน้ำเงิน

ความหนา 1 มิลลิเมตร (mm)

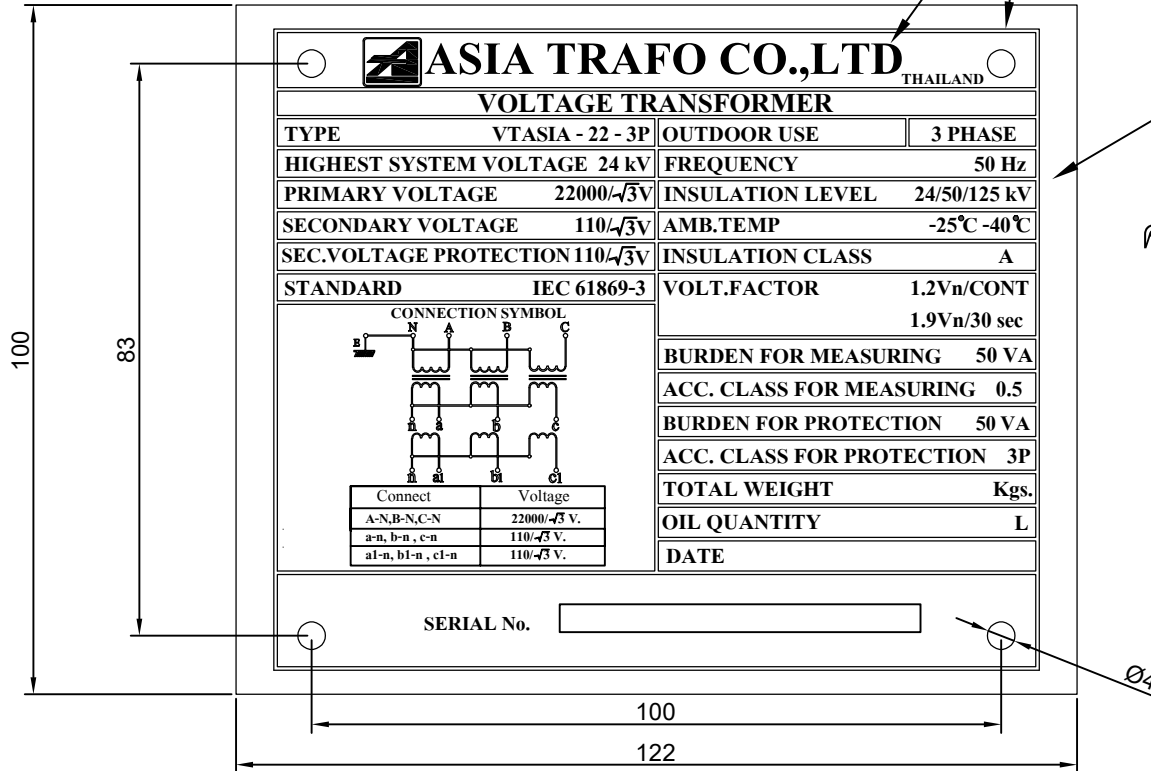

บริษัท เอเชีย ทราฟ จำกัด ASIA TRAF0 CO.,LTD	MODEL/DESCRIPTION :		VT 3P 33000/sqr3 -110/sqr3-110sqr3 V
	DWG.No :		3P-33-02
DIMENSION IN MILLIMETER		WORK NO :	QTY..... EA
	DESIGNED	NAME	DATE
	CHECK	รัฐมนตรา	12/6/2566
Rev No.	Revision Note.	APPROVED	กิตติ
		กิตติ	12/6/2566
		REV : 00	SHEET 1 OF 1